

# Multiple Access Channel with Various Degrees of Asymmetric State Information

Nevroz Şen  
Queen's University  
nsen@mast.queensu.ca

Fady Alajaji  
Queen's University  
fady@mast.queensu.ca

Serdar Yüksel  
Queen's University  
yukse@mast.queensu.ca

Giacomo Como  
Lund University  
giacomo@control.lth.se

**Abstract**—We consider the problem of reliable communication over multiple-access channels (MAC) where the channel is driven by an independent and identically distributed state process and the encoders and the decoder are provided with various degrees of asymmetric (noisy or partial) channel state information (CSI). Namely, we provide a single letter characterization for the capacity region when the encoders have access to non-causal asymmetric partial CSI and the decoder has complete CSI. When the encoders observe asymmetric noisy CSI with asymmetric delays and the decoder observes complete CSI, we provide a single letter characterization for the capacity region. Finally, we consider a cooperative scenario with common and private messages, with noisy CSIT and complete CSIR and provide a single letter expression for the capacity region. For the cooperative scenario, we also note that as soon as the common message encoder does not have access to CSI, then for any noisy CSIT and CSIR setup it is possible to obtain a single letter characterization for the capacity region.

## I. INTRODUCTION AND LITERATURE REVIEW

Channels which are controlled by a state process have been widely studied for both single and multi-user channels. For single-user channels, Shannon [2] provides the capacity formula with causal noiseless CSIT, where the state process is i.i.d., and [3] extends Shannon's result to the noisy CSIT and the noisy CSIR case, which is later shown to be a special case of Shannon's model [4].

The literature on FS-MAC with different assumptions of CSIT and CSIR is extensive and the main contributions of the current paper have several interactions with the results in the literature, which we present in Subsection I-A. Hence, we discuss the relevant literature for the multi-user setting in more detail. To start, [5] provides a multi-letter characterization of the capacity region of time-varying MACs with general channel statistics (with/without memory) under a general state process (not necessarily stationary or ergodic) and with various degrees of CSIT and CSIR. In [6], a general framework for the capacity region of MACs with causal and non-causal CSI is presented. In particular, an achievable rate region is presented for the memoryless FS-MAC with correlated CSI and the sum-rate capacity is established under the condition that the state information available to each encoder are independent. This result is extended to a correlated setup in [7]. In [8], MACs with complete CSIR and noncausal, partial, rate limited CSITs

are considered. In particular, for the degraded case, a single letter formula for the capacity region is provided and when the CSITs are not degraded, inner and outer bounds are derived, see [8, Theorems 1, 2]. Another active research direction on the FS-MAC regards the so-called cooperative FS-MAC where there exists a degraded condition on the message sets. In particular, [9] and [10] characterize the capacity region of the cooperative FS-MAC with states non-causally and causally available at the transmitters. For more recent results on the FS-MAC problem see [11]-[14].

### A. Main Contributions and Connections with the Literature

We consider several scenarios where the encoders and the decoder observe various degrees of asymmetric (noisy or partial) CSI. For the noisy CSI, the essential requirement we impose is that the noisy CSI available to the encoders is realized via the corruption of CSI by different noise processes, which give a realistic physical structure of the communication setup. We herein note that the asymmetric noisy CSI assumption is plausible as typically the feedback links are imperfect and sufficiently far from each other so that the information carried through them is corrupted by different (independent) noise processes. What makes (asymmetric) noisy setups particularly interesting are the facts that

- (a) No transmitter's CSI contains the CSI at the other one;
- (b) CSIR does not contain any of the CSITs;

and when existing results, which give a single letter capacity formulation, are examined, it can be seen that most of them do not satisfy (a) or (b) or both (e.g., [1], [5], [6], [8], [12]).

With this motivation, we treat the scenarios below and provide single letter characterizations for their capacity regions:

- (1) The FS-MAC with asymmetric non-causal partial CSITs and complete CSIR (Theorem 1).
- (2) The FS-MAC with asymmetrically delayed and asymmetric noisy CSITs and CSIR (Theorem 2).
- (3) The cooperative FS-MAC in which both encoders transmit a common message and one transmitter (informed transmitter) transmits an additional private message. The informed encoder has causal noisy CSI, the other encoder has a delayed noisy CSI and the receiver has various degrees of CSI (Theorems 3 and 4).

The solution that we provide to (1) solves [8, Theorem 2] without rate constraints on the coded side information and

extends [6, Theorem 5] to the case where the encoders have correlated CSI. Furthermore, since the causal and non-causal capacities are identical for scenario (1), it can be considered as an extension of [4, Proposition 1] to a noisy multi-user case. Finally, (3) is an extension of [9, Theorem 4] to a noisy setup.

### B. The Converse Coding Approach

The main component in this paper is a generalization of the converse coding approach recently introduced in [1] and herein considerably extended and adapted for the noisy CSI setup. The converse coding approach of [1] is based on using *memoryless stationary team policies* which play a key role in showing that the past information is irrelevant. This is obtained by showing that under any policy that one can achieve using an arbitrary decentralized coding policy, the same performance can be achieved by using memoryless stationary team policies. However, as the authors mention in [1, Remark 2], the arguments in their paper hold if the state information available at the decoder contains the one available at the two transmitters. In this way, the decoder does not need to estimate the coding policies used under decentralized time-sharing.

For the noisy setup, we need to modify this approach to account for the fact that the decoder does not have access to the CSITs, and that the past state information does not lead to a tractable recursion.

The rest of the paper is organized as follows. In Section II, we present notation and preliminaries, in Sections III, IV and V, we formally state scenarios (1), (2) and (3), respectively, and present the main results and several observations. In Section VI, we present concluding remarks. The proofs of all our results are available in detail in [15].

## II. NOTATION AND PRELIMINARIES

Throughout the paper, a random variable will be denoted by an upper case letter  $X$  and its particular realization by a lower case letter  $x$ . For a vector  $v$ , and a positive integer  $i$ ,  $v_i$  will denote the  $i$ -th entry of  $v$ , while  $v_{[i]} = (v_1, \dots, v_i)$  and  $v_{[i,j]} = (v_i, \dots, v_j)$ ,  $i \leq j$ . For a finite set  $\mathcal{A}$ ,  $\mathcal{P}(\mathcal{A})$  will denote the simplex of probability distributions over  $\mathcal{A}$ . Probability distributions are denoted by  $P(\cdot)$  and subscripted by the name of the random variables and conditioning, e.g.,  $P_{U,T|V,S}(u, t|v, s)$  is the conditional probability of  $(U = u, T = t)$  given  $(V = v, S = s)$ . All sets considered hereafter are finite.

We consider a two-user memoryless FS-MAC, with two encoders,  $a, b$ , and two independent message sources  $W_a$  and  $W_b$  which are uniformly distributed in the sets  $W_a \in \{1, 2, \dots, |\mathcal{W}_a|\}$  and  $W_b \in \{1, 2, \dots, |\mathcal{W}_b|\}$ , respectively. The channel inputs of the encoders are  $X^a \in \mathcal{X}_a$  and  $X^b \in \mathcal{X}_b$ , respectively. The channel state process is modeled as a sequence  $\{S_t\}_{t=1}^{\infty}$  of i.i.d. random variables in some space  $\mathcal{S}$ . Let the CSI at the two encoders be modeled by  $S_t^a \in \mathcal{S}_a$ ,  $S_t^b \in \mathcal{S}_b$ , respectively, for  $t \geq 1$ . Depending on the scenario,  $S_t^i$ ,  $i = \{a, b\}$ , shall denote either the partial or the

noisy CSITs, which we will explicitly mention in each section. The asymmetric partial CSITs are obtained via deterministic mappings;  $S_t^a = \beta^a(S_t)$  and  $S_t^b = \beta^b(S_t)$ , where  $\beta^i : \mathcal{S} \rightarrow \mathcal{S}_i$ ,  $i = \{a, b\}$ , can be considered as quantizers.

When the CSITs are asymmetric noisy versions of  $S_t$ , we assume that the joint distribution of  $(S_t, S_t^a, S_t^b)$  factorizes as

$$P_{S_t^a, S_t^b, S_t}(s_t^a, s_t^b, s_t) = P_{S_t^a|S_t}(s_t^a|s_t)P_{S_t^b|S_t}(s_t^b|s_t)P_{S_t}(s_t) \quad (1)$$

and that  $\{(S_t, S_t^a, S_t^b)\}_{t=1}^{\infty}$  is a sequence of i.i.d. triples and independent from  $(W_a, W_b)$ ;

$$\begin{aligned} P_{S_{[n]}, S_{[n]}^a, S_{[n]}^b, W_a, W_b}(s_{[n]}, s_{[n]}^a, s_{[n]}^b, w_a, w_b) \\ = \prod_{t=1}^n \frac{1}{|\mathcal{W}_a|} \frac{1}{|\mathcal{W}_b|} P_{S_t^a|S_t}(s_t^a|s_t) P_{S_t^b|S_t}(s_t^b|s_t) P_{S_t}(s_t). \end{aligned} \quad (2)$$

Let  $\mathbf{W} := (W_a, W_b)$  and  $\mathbf{X} := (X^a, X^b)$ . The channel is memoryless and hence,

$$\begin{aligned} P_{Y_{[n]}|\mathbf{W}, \mathbf{X}_{[n]}, S_{[n]}, S_{[n]}^a, S_{[n]}^b}(y_{[n]}|\mathbf{w}, \mathbf{x}_{[n]}, s_{[n]}, s_{[n]}^a, s_{[n]}^b) \\ = \prod_{t=1}^n P_{Y_t|X_t^a, X_t^b, S_t}(y_t|x_t^a, x_t^b, s_t), \end{aligned} \quad (3)$$

where the channel's transition probability distribution,  $P_{Y_t|X_t^a, X_t^b, S_t}(y_t|x_t^a, x_t^b, s_t)$ , is given a priori.

When CSITs are causal, we shall use Shannon strategies [2]: Let the set of all possible functions from  $\mathcal{S}_a$  to  $\mathcal{X}_a$  and  $\mathcal{S}_b$  to  $\mathcal{X}_b$  be denoted by  $\mathcal{T}_a := \mathcal{X}_a^{\mathcal{S}_a}$  and  $\mathcal{T}_b := \mathcal{X}_b^{\mathcal{S}_b}$ , respectively. We refer to  $\mathcal{T}_a$ -valued and  $\mathcal{T}_b$ -valued random vectors as Shannon strategies.

We next introduce *memoryless stationary team policies* [1] which will be invoked in the main results of this paper.

*Definition 1:* A memoryless stationary (in time) team policy is a family of one of

$$\Pi = \{\pi = (\pi_{T^a}(\cdot), \pi_{T^b}(\cdot)) \in \mathcal{P}(\mathcal{T}_a) \times \mathcal{P}(\mathcal{T}_b)\} \quad (4)$$

$$\bar{\Pi} = \{\bar{\pi} = (\pi_{X^a|S^a}(\cdot|\beta^a(s)), \pi_{X^b|S^b}(\cdot|\beta^b(s))) \in \mathcal{P}(\mathcal{X}_a) \times \mathcal{P}(\mathcal{X}_b)\} \quad (5)$$

$$\tilde{\Pi} = \{\tilde{\pi} = (\pi_{X^a}(\cdot), \pi_{X^b}(\cdot)) \in \mathcal{P}(\mathcal{X}_a) \times \mathcal{P}(\mathcal{X}_b)\} \quad (6)$$

$$\hat{\Pi} = \{\hat{\pi} = (\pi_{X^a, T^b}(\cdot, \cdot)) \in \mathcal{P}(\mathcal{X}_a \times \mathcal{T}_b)\} \quad (7)$$

probability distributions on the appropriate sets.

Finally, for a region  $\mathcal{R}(\alpha)$ ,  $\overline{\text{co}}\left(\bigcup_{\alpha \in \Lambda} \mathcal{R}(\alpha)\right)$  denotes the closure of the convex hull of the regions  $\mathcal{R}(\alpha)$  associated to all possible  $\alpha \in \Lambda$ .

We now present the main results. Note that the first section considers the case where the encoders observe asymmetric, partial CSI non-causally. In the other sections, CSITs are noisy versions of  $S_t$ .

## III. ASYMMETRIC NON-CAUSAL PARTIAL CSIT AND COMPLETE CSIR

Let  $S_t^a = \beta^a(S_t)$  and  $S_t^b = \beta^b(S_t)$  and assume also that  $S_t$  is fully available at the receiver; see Fig. 1. The channel inputs at time  $t$  are, i.e.  $X_t^a$  and  $X_t^b$ , are functions of the locally available information  $(W_a, S_{[n]}^a)$  and  $(W_b, S_{[n]}^b)$ , respectively.

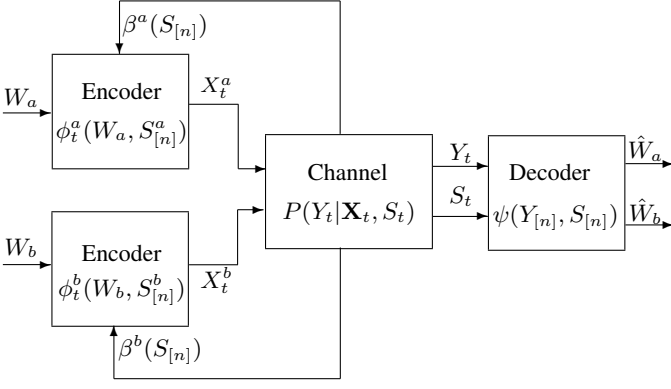

Fig. 1. The multiple-access channel with partial state feedback.

**Definition 2:** An  $(n, 2^{nR_a}, 2^{nR_b})$  code with block length  $n$  and rates  $(R_a, R_b)$  for an FS-MAC with partial state feedback consists of

- (1) A sequence of mappings for each encoder

$$\begin{aligned} \phi_t^{(a)} &: \mathcal{S}_a^n \times \mathcal{W}_a \rightarrow \mathcal{X}_a^n \\ \phi_t^{(b)} &: \mathcal{S}_b^n \times \mathcal{W}_b \rightarrow \mathcal{X}_b^n. \end{aligned}$$

- (2) An associated decoding function

$$\psi : \mathcal{S}^n \times \mathcal{Y}^n \rightarrow \mathcal{W}_a \times \mathcal{W}_b.$$

The system's probability of error,  $P_e^{(n)}$ , is given by

$$\frac{1}{2^{n(R_a+R_b)}} \sum_{w_a=1}^{2^{nR_a}} \sum_{w_b=1}^{2^{nR_b}} P(\psi(Y_{[n]}, S_{[n]}) \neq (w_a, w_b) | \mathbf{W} = \mathbf{w}).$$

A rate pair  $(R_a, R_b)$  is achievable if for any  $\epsilon > 0$  there exists, for all  $n$  sufficiently large, an  $(n, 2^{nR_a}, 2^{nR_b})$  code such that  $\frac{1}{n} \log |\mathcal{W}_a| \geq R_a \geq 0$ ,  $\frac{1}{n} \log |\mathcal{W}_b| \geq R_b \geq 0$  and  $P_e^{(n)} \leq \epsilon$ . The capacity region,  $\mathcal{C}_{NC}$ , is the closure of the set of all achievable rate pairs  $(R_a, R_b)$ .

For every  $\bar{\pi}$  defined in (5),  $\mathcal{R}_{NC}(\bar{\pi})$  denotes the region of all rate pairs  $R = (R_a, R_b)$  satisfying

$$R_a < I(X^a; Y | X^b, S) \quad (8)$$

$$R_b < I(X^b; Y | X^a, S) \quad (9)$$

$$R_a + R_b < I(X^a, X^b; Y | S) \quad (10)$$

where  $S, X^a, X^b$  and  $Y$  are random variables taking values in  $\mathcal{S}, \mathcal{X}_a, \mathcal{X}_b$  and  $\mathcal{Y}$ , respectively, and whose joint probability distribution factorizes as

$$\begin{aligned} P_{S, X^a, X^b, Y}(s, x^a, x^b, y) &= P_S(s) P_{Y|X^a, X^b, S}(y | x^a, x^b, s) \\ &\times \pi_{X^a|S^a}(x^a | \beta^a(s)) \pi_{X^b|S^b}(x^b | \beta^b(s)). \end{aligned} \quad (11)$$

$$\text{Theorem 1: } \mathcal{C}_{NC} = \overline{\text{co}} \left( \bigcup_{\bar{\pi} \in \bar{\Pi}} \mathcal{R}_{NC}(\bar{\pi}) \right).$$

For the achievability proof, see [1, Section III] and observe that any rate which is achievable with causal CSI is also achievable with non-causal CSI. For the converse proof see [15, Appendix A]. The proof for the non-causal case is realized by observing that there is no loss of optimality if not only the past, as shown in [1], but also the future CSI is ignored given that the receiver is provided with complete CSI.

*Remark 1:* Following [1, Remark 1], it is worth to emphasize that for the above argument to work, it is crucial that CSIR contains the CSITs. In particular, this fact plays a role in the converse part of the coding theorem by enabling the decoder to ignore the past channel outputs, without any loss of optimality.

#### A. Non-causal Extension of a Noisy Setup

Let us consider the scenario considered in [7] where the two encoders observe causal asymmetric noisy version of CSI,  $S_t^a, S_t^b$ , respectively, whose joint distribution satisfy (1) and the decoder has complete CSI. Although the full capacity region is not known, it is shown in [7] that the sum rate capacity is given by  $\sup_{\pi_{T^a}(t^a)\pi_{T^b}(t^b)} I(T^a, T^b; Y | S)$ . Obviously, the CSIR does not contain the CSITs. We now demonstrate that if the encoders in this setup observe noisy CSI non-causally, then it is not guaranteed that the Shannon strategies are optimal, for the sum-rate capacity. The reason for this is that Remark 1 is violated.

For the converse, using Fano's inequality and standard steps we get  $R_a + R_b \leq \frac{1}{n} I(\mathbf{W}; Y_{[n]}, S_{[n]}) + \epsilon_n$ , where  $\lim_{\epsilon \rightarrow 0} \epsilon_n = 0$ . Let us now consider the term  $I(\mathbf{W}; Y_{[n]}, S_{[n]})$ . We have

$$\begin{aligned} I(\mathbf{W}; Y_{[n]}, S_{[n]}) &= \sum_{t=1}^n [H(Y_t | S_{[n]}, Y_{[t-1]}) - H(Y_t | \mathbf{W}, S_{[n]}, Y_{[t-1]})] \\ &\leq \sum_{t=1}^n [H(Y_t | S_{[n]}, Y_{[t-1]}) - H(Y_t | \mathbf{W}, S_{[n]}, Y_{[t-1]}, \mathbf{T}_t)] \end{aligned} \quad (12)$$

where  $\mathbf{T}_t := (T_t^a, T_t^b)$ . Observe now that, given the full CSI and Shannon strategies, the past channel output information is not useless in the non-causal setup. This is because, we have

$$\begin{aligned} P_{Y_t | \mathbf{W}, S_{[n]}, Y_{[t-1]}, T_t^a, T_t^b}(y_t | \mathbf{w}, s_{[n]}, y_{[t-1]}, t_t^a, t_t^b) &= \sum_{s_t^a, s_t^b} P_{Y_t | S_t, S_t^a, S_t^b, T_t^a, T_t^b}(y_t | s_t, s_t^a, s_t^b, t_t^a, t_t^b) \\ &\quad \times P_{S_t^a, S_t^b | Y_{[t-1]}, S_t}(s_t^a, s_t^b | y_{[t-1]}, s_t), \end{aligned}$$

where the equality is verified by (3), and therefore, the past channel outputs can not be ignored, which was one of the main reasons of optimality of Shannon strategies in the causal noisy setup.

#### IV. ASYMMETRIC DELAYED, ASYMMETRIC NOISY CSIT AND COMPLETE CSIR

Let the two encoders have accesses to asymmetrically delayed, where delays are  $d_a \geq 1$  and  $d_b \geq 1$ , respectively, and noisy versions of the state information  $S_t$  at each time  $t \geq 1$ ,  $S_{t-d_a}^a \in \mathcal{S}_a$ ,  $S_{t-d_b}^b \in \mathcal{S}_b$ , respectively. Hence, the model satisfies (1), (2) and (3). We also assume that  $S_t$  is fully available at the receiver. A code can be defined as in Definition 2, except now

$$\phi_t^{(a)} : \mathcal{S}_a^{t-d_a} \times \mathcal{W}_a \rightarrow \mathcal{X}_a, \quad t = 1, 2, \dots, n;$$

$$\phi_t^{(b)} : \mathcal{S}_b^{t-d_b} \times \mathcal{W}_b \rightarrow \mathcal{X}_b, \quad t = 1, 2, \dots, n.^1$$

Let  $\mathcal{C}_{DN}$  denotes the capacity region of the delayed setup. For every memoryless stationary team policy  $\tilde{\pi}$ ,  $\mathcal{R}_{DN}(\tilde{\pi})$  denotes the region of all rate pairs  $R = (R_a, R_b)$  satisfying

$$R_a < I(X^a; Y|X^b, S) \quad (13)$$

$$R_b < I(X^b; Y|X^a, S) \quad (14)$$

$$R_a + R_b < I(X^a, X^b; Y|S) \quad (15)$$

where  $S$ ,  $X^a$ ,  $X^b$  and  $Y$  are random variables taking values in  $\mathcal{S}$ ,  $\mathcal{X}^a$ ,  $\mathcal{X}^b$  and  $\mathcal{Y}$ , respectively and whose joint probability distribution factorizes as

$$\begin{aligned} P_{S, X^a, X^b, Y}(s, x^a, x^b, y) \\ = P_S(s)P_{Y|X^a, X^b, S}(y|x^a, x^b, s)\pi_{X^a}(x^a)\pi_{X^b}(x^b). \end{aligned} \quad (16)$$

$$\textit{Theorem 2: } \mathcal{C}_{DN} = \overline{\text{co}} \left( \bigcup_{\tilde{\pi} \in \tilde{\Pi}} \mathcal{R}_{DN}(\tilde{\pi}) \right).$$

See [15, Appendix B] for the proofs.

*Remark 2 (Strictly Causal Case):* When  $d_a = d_b = 1$ , Theorem 2 is the capacity region of the setup with strictly causal noisy CSITs. In [11], achievable rate region is provided for the case when the channel is driven by two independent states (with no CSIR). When the encoders have strictly causal CSI (not noisy/not asymmetric), the authors proposed a region which is based on sending a compressed version of the CSITs to the decoder. Theorem 2 verifies that since the full CSI is available at the receiver there exists no loss of optimality if the past information at the encoders is ignored.

Finally, for an asymmetric delayed CSIT setup of an FS-MAC with Markovian state process see [12].

## V. COOPERATIVE FS-MAC WITH NOISY CSIT

Assume a common message is provided to both encoders and one of the encoders has its own private message. Assume further that the encoder with the private message causally observes noisy state information, whereas the encoder with the common message only observes noisy state information with delay  $d_a \geq 1$ . Let the common and the private messages be  $W_a$  and  $W_b$ , respectively, and  $S_{[t-d_a]}^a$ ,  $d_a \geq 1$ , and  $S_{[t]}^b$  denote the noisy CSI at encoder  $a$ ,  $b$ , respectively, where  $(S_t, S_t^a, S_t^b)$  satisfies (1) and (2). Hence,  $X_t^a = \phi_t^{(a)}(W_a, S_{[t-d_a]}^a)$  and  $X_t^b = \phi_t^{(b)}(W_a, W_b, S_{[t]}^b)$ ; see Fig. 2. Let  $\mathcal{C}_C$  denote the capacity region for this channel. Let for every  $\hat{\pi}$ ,  $\mathcal{R}_C(\hat{\pi})$  denote the region of all rate pairs  $R = (R_a, R_b)$  satisfying

$$R_b < I(T^b; Y|X^a, S) \quad (17)$$

$$R_a + R_b < I(X^a, T^b; Y|S) \quad (18)$$

where  $S$ ,  $X^a$ ,  $T^b$  and  $Y$  are random variables taking values in  $\mathcal{S}$ ,  $\mathcal{X}_a$ ,  $\mathcal{T}_b$  and  $\mathcal{Y}$ , respectively and whose joint probability distribution factorizes as

$$\begin{aligned} P_{S, X^a, T^b, Y}(s, x^a, t^b, y) \\ = P_S(s)P_{Y|X^a, T^b, S}(y|x^a, t^b, s)\pi_{X^a, T^b}(x^a, t^b). \end{aligned} \quad (19)$$

<sup>1</sup>Obviously, when  $d_l \geq t$ ,  $l = a, b$  then  $X_t^a = \phi_t^{(a)}(W_a)$  and  $X_t^b = \phi_t^{(b)}(W_b)$ .

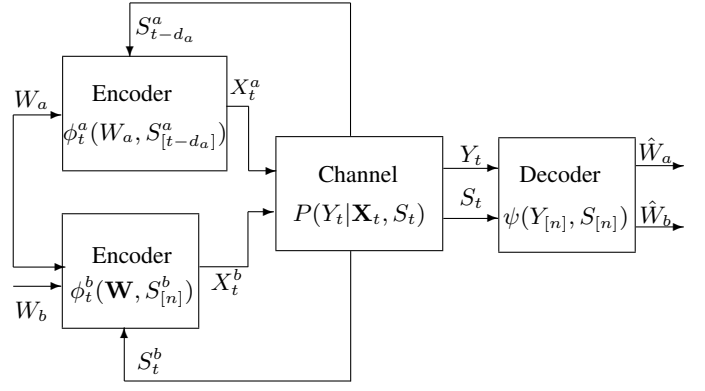

Fig. 2. Cooperative multiple-access channel with noisy state feedback.

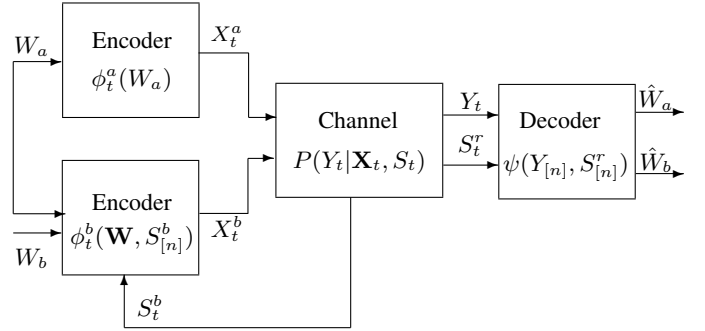

Fig. 3. Cooperative multiple-access channel with noisy CSIT and CSIR.

$$\textit{Theorem 3: } \mathcal{C}_C = \overline{\text{co}} \left( \bigcup_{\hat{\pi} \in \hat{\Pi}} \mathcal{R}_C(\hat{\pi}) \right).$$

See [15, Appendix C] for the proof.

One important observation to be made in the cooperative scenario is that we do not require a product form on the pair  $(X^a, T^b)$  (see (19)). In connection with this observation, let us consider the following noisy CSIR setup.

Let the encoder with the private message causally observe noisy CSI, whereas the encoder with the common message has no CSI, i.e.,  $X_t^a = \phi_t^{(a)}(W_a)$  and  $X_t^b = \phi_t^{(b)}(W_a, W_b, S_{[t]}^b)$ , and the decoder also has access to noisy CSI at time  $t$ ,  $S_t^r \in \mathcal{S}_r$ ; see Fig. 3. Let  $\mathcal{C}_C^G$  denote the capacity region for this setup. Let for every memoryless stationary team policy  $\hat{\pi}$  defined in (7),  $\mathcal{R}_C^G(\hat{\pi})$  denote the region of all rate pairs  $R = (R_a, R_b)$  satisfying,

$$R_b < I(T^b; Y|X^a, S^r) \quad (20)$$

$$R_a + R_b < I(X^a, T^b; Y|S^r) \quad (21)$$

where  $S^r$ ,  $X^a$ ,  $T^b$  and  $Y$  are random variables taking values in  $\mathcal{S}_r$ ,  $\mathcal{X}_a$ ,  $\mathcal{T}_b$  and  $\mathcal{Y}$ , respectively and whose joint probability distribution factorizes as

$$\begin{aligned} P_{S^r, X^a, T^b, Y}(s^r, x^a, t^b, y) \\ = P_{S^r}(s^r)P_{Y|X^a, T^b, S^r}(y|x^a, t^b, s^r)\pi_{X^a, T^b}(x^a, t^b). \end{aligned} \quad (22)$$

$$\textit{Theorem 4: } \mathcal{C}_C^G = \overline{\text{co}} \left( \bigcup_{\hat{\pi} \in \hat{\Pi}} \mathcal{R}_C^G(\hat{\pi}) \right).$$

See [15, Section IV] for the proof.

*Remark 3:* It should be observed that unlike Theorem 3 and results in the previous sections, for the validity of Theorem 4, it is not required to have a Markov condition on  $P_{S_t, S_t^b, S_t^r}(s_t, s_t^b, s_t^r)$  such as the one given in (1). Furthermore, the result also holds with no CSIR, i.e.,  $\mathcal{S}_r = \emptyset$  is allowed, and in this case Theorem 4 is as an extension of [9, Theorem 4] to a noisy setup.

Note that for the setup given in [9, Theorem 4], Theorem 4 provides an equivalent characterization. Recall that in [9, Theorem 4] the informed encoder has full CSI, i.e.,  $X_t^b = \phi_t^{(b)}(W_a, W_b, S_{[t]})$ , both the uniformed encoder and the decoder has no CSI and the capacity region,  $\mathcal{C}_{AS}$ , is given as the closure of all rate pairs  $(R_a, R_b)$  satisfying

$$R_b < I(U; Y|X^a) \quad (23)$$

$$R_b + R_a < I(U, X^a; Y) \quad (24)$$

for some joint measure on  $\mathcal{S} \times \mathcal{X}_a \times \mathcal{X}_b \times \mathcal{Y} \times \mathcal{U}$  having the form

$$P_{Y|X^a, X^b, S}(y|x^a, x^b, s)P_{X^b|U, X^a, S}(x^b|u, x^a, s) \times P_S(s)P_{X^a, U}(x^a, u), \quad (25)$$

where  $|\mathcal{U}| \leq |\mathcal{S}||\mathcal{X}_a||\mathcal{X}_b| + 1$ . On the other hand, for this setup, Theorem 4 gives the capacity region,  $\mathcal{C}_{FS}^G$ , as  $\overline{\text{co}}\left(\bigcup_{\hat{\pi}} \mathcal{R}'_C(\hat{\pi})\right)$  where  $\mathcal{R}'_C(\hat{\pi})$  denotes the region of all rate pairs  $R = (R_a, R_b)$  satisfying

$$R_b < I(T; Y|X^a) \quad (26)$$

$$R_a + R_b < I(T, X^a; Y) \quad (27)$$

where  $P_{Y, T, X^a, X^b, S}(y, t, x^a, x^b, s)$  factorizes as

$$P_{Y|X^a, X^b, S}(y|x^a, x^b, s)P_{X^b|S, T}(x^b|s, t)P_S(s)\hat{\pi}_{X^a, T}(x^a, t),$$

and  $T: \mathcal{S} \rightarrow \mathcal{X}_b$ .

For the proof of  $\mathcal{C}_{FS}^G = \mathcal{C}_{AS}$ , see [15, Appendix D]. Note that for this multi-user setup, the relation between the auxiliary variable and Shannon strategies requires more attention; in particular, note the difference between  $|\mathcal{U}|$  and  $|\mathcal{T}|$ .

We conclude this section with the following remark.

*Remark 4:* For the validity of Theorem 4 it is crucial that  $X_t^a$  only depends on  $W_a$ . To be more explicit, let us assume  $\mathcal{S}_r = \emptyset$  and consider the following steps of the converse

$$\begin{aligned} & I(W_b; Y_{[n]}) \\ & \leq \sum_{t=1}^n H(Y_t|Y_{[t-1]}, X_{[n]}^a) - H(Y_t|Y_{[t-1]}, \mathbf{W}, X_{[n]}^a, T_t^b) \\ & = \sum_{t=1}^n H(Y_t|Y_{[t-1]}, X_{[n]}^a) - H(Y_t|Y_{[t-1]}, X_t^a, T_t^b). \end{aligned} \quad (28)$$

Since  $S_t$  is not available to the decoder, the above equality is valid if and only if  $X_{[n]}^a$  does not provide any information about  $S_t$ . Hence, whether CSITs are noisy or not, if there is no CSI or noisy CSI at the decoder, the arguments above would fail if the uninformed encoder observes some degree of

CSI, i.e.,  $d_a < \infty$  so that  $X_{[n]}^a$  carry some information about  $(S_t, S_t^b, S_t^r)$ .

## VI. CONCLUSION AND REMARKS

We have considered several scenarios for the memoryless FS-MAC with various degrees of asymmetric (noisy and partial) CSIT and complete and noisy CSIR. We obtain single letter characterizations for the capacity regions when the encoders observe non-causal, partial asymmetric CSI and when the CSITs are asymmetric noisy and asymmetrically delayed. We further discuss a cooperative scenario and show that when the common message encoder does not have an access to the current noisy CSI, due to delay, it is possible to obtain a single letter expression for the capacity region. Since a product form is not required in a cooperative scenario, we observed that as soon as the common message encoder does not have access to CSI, then in any noisy setup, covering the cases where no CSIR or noisy CSIR, it is possible to obtain a single letter expression for the capacity region.

## REFERENCES

- [1] G. Como and S. Yüksel, "On the capacity of memoryless finite state multiple access channels with asymmetric state information at the encoders," *IEEE Trans. Inform. Theory*, vol. 57, no. 3, pp. 1267-1273, March 2011.
- [2] C. E. Shannon, "Channels with side information at the transmitter," *IBM J. Res. Develop.*, vol. 2, pp. 289-293, 1958.
- [3] M. Salehi, "Capacity and coding for memories with real-time noisy defect information at encoder and decoder," *IEE-Proceedings-1* vol. 139, pp. 113-117, Apr. 1992.
- [4] G. Caire and S. Shamai, "On the capacity of some channels with channel state information," *IEEE Trans. Inform. Theory*, vol. 45, no. 6, pp. 2007-2019, Sep. 1999.
- [5] A. Das and P. Narayan, "Capacities of time-varying multiple access channels with side information," *IEEE Trans. Inform. Theory*, vol. 48, no. 1, pp. 4-25, Jan. 2002.
- [6] S. A. Jafar, "Capacity with casual and non-casual side information-a unified view," *IEEE Trans. Inform. Theory*, vol. 52 no. 12, pp. 5468-5474, Dec. 2006.
- [7] N. Şen, G. Como, S. Yüksel and F. Alajaji, "On the Capacity of Memoryless Finite-State Multiple Access Channels with Asymmetric Noisy State Information at the Encoders," *Proc. Allerton Conf. Comm. Cont. and Comp.* Monticello, IL, September 2011.
- [8] Y. CemaI and Y. Steinberg, "The multiple-access channel with partial state information at the encoders," *IEEE Trans. Inform. Theory*, vol. 51, no. 11, pp. 3992-4003, Nov. 2005.
- [9] A. Somekh-Baruch, S. Shamai and S. Verdú, "Cooperative multiple-access encoding with states available at one transmitter," *IEEE Trans. Inform. Theory*, vol. 54, no. 10, pp. 4448-4469, Oct. 2008.
- [10] S. Kotagiri and J. Laneman, "Multiaccess channels with state known to one encoder: A case of degraded message sets," *Proc. IEEE Int. Symp. Information Theory* Nice, France, pp. 1566-1570, June 2007.
- [11] A. Lapidoth and Y. Steinberg, "The multiple-access channel with two independent states each known causally to one encoder," *Proc. IEEE Int. Symp. Information Theory* Austin, Texas, U.S.A, June 2010.
- [12] U. Basher, A. Shirazi and H. Permuter, "Capacity region of finite state multiple-access channel with delayed state information at the transmitters," available at [arXiv:1101.2389].
- [13] A. Zaidi, P. Piantanida and S. Shamai, "Multiple access channel with states known noncausally at one encoder and only strictly causally at the other encoder," *Proc. IEEE Int. Symp. Information Theory* St. Petersburg, Russia, July 2011.
- [14] H. Permuter, S. Shamai and A. Somekh-Baruch, "Message and state cooperation in multiple access channels," *IEEE Trans. Inform. Theory*, vol. 57, no. 10, pp. 6379-6396, Oct. 2011.
- [15] N. Şen, F. Alajaji, S. Yüksel and G. Como, "On the multiple access channel with asymmetric noisy state information at the encoders," *Submitted to IEEE Trans. Inform. Theory*, Jan. 2012, available at [arXiv:1201.4109].